

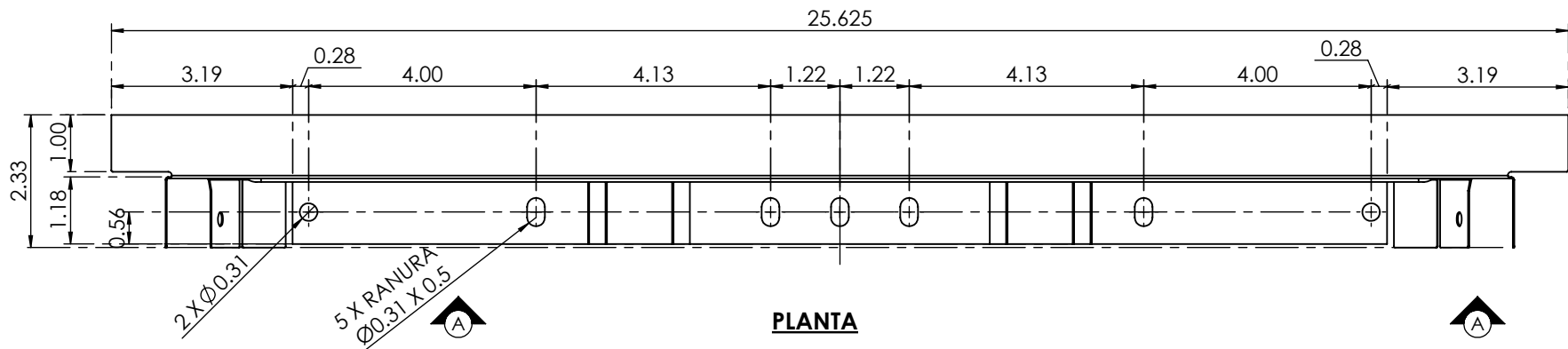

LISTA DE MATERIALES				
NORMA/MATERIAL	GRADO	CALIBRE	ACABADO	PESO /UNIT.
ASTM A653	40	24	PINTRO BLANCO ESTANDAR	0.07 Kg

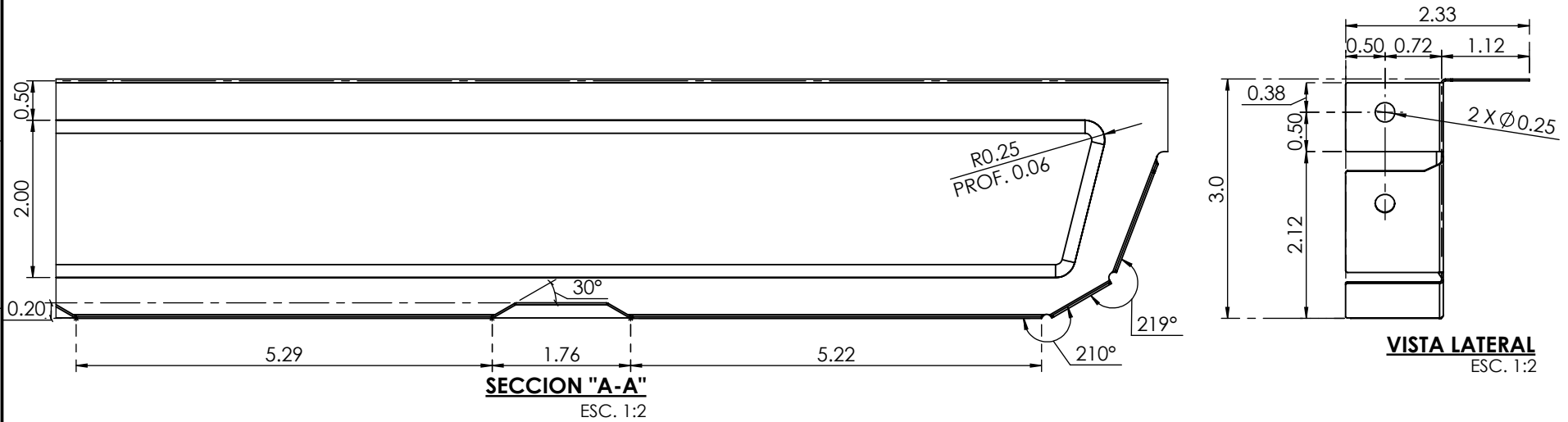

REVISIONES				
ZONA	REV.	DESCRIPCIÓN	FECHA	APROBADO

COTAS: PULGADAS FECHA: 02/DIC/2020 APROBO: L.G.C.R. HOJA: 1 DE 3 DIBUJO No: AG-CE	ESCALA: 1:3 DIBUJO: E.M.R.E. REVISO: A.C.E./J.A.A. FIRMA:	DESCRIPCION: CLOSURE EXTERIOR TOLERANCIAS: FRACCION ± 1/32" DECIMAL ± 0.03" METRICO ± 0.008mm ANGULAR ± 1°		
	REVISION: 0 TROQUELES DE REFERENCIA:			FR-PROD-05 FICHA TECNICA DE PRODUCTO
	REV. 0			

LISTA DE MATERIALES				
NORMA/MATERIAL	GRADO	CALIBRE	ACABADO	PESO/UNIT.
ASTM A653	40	24	PINTRO BLANCO ESTANDAR	0.07 Kg

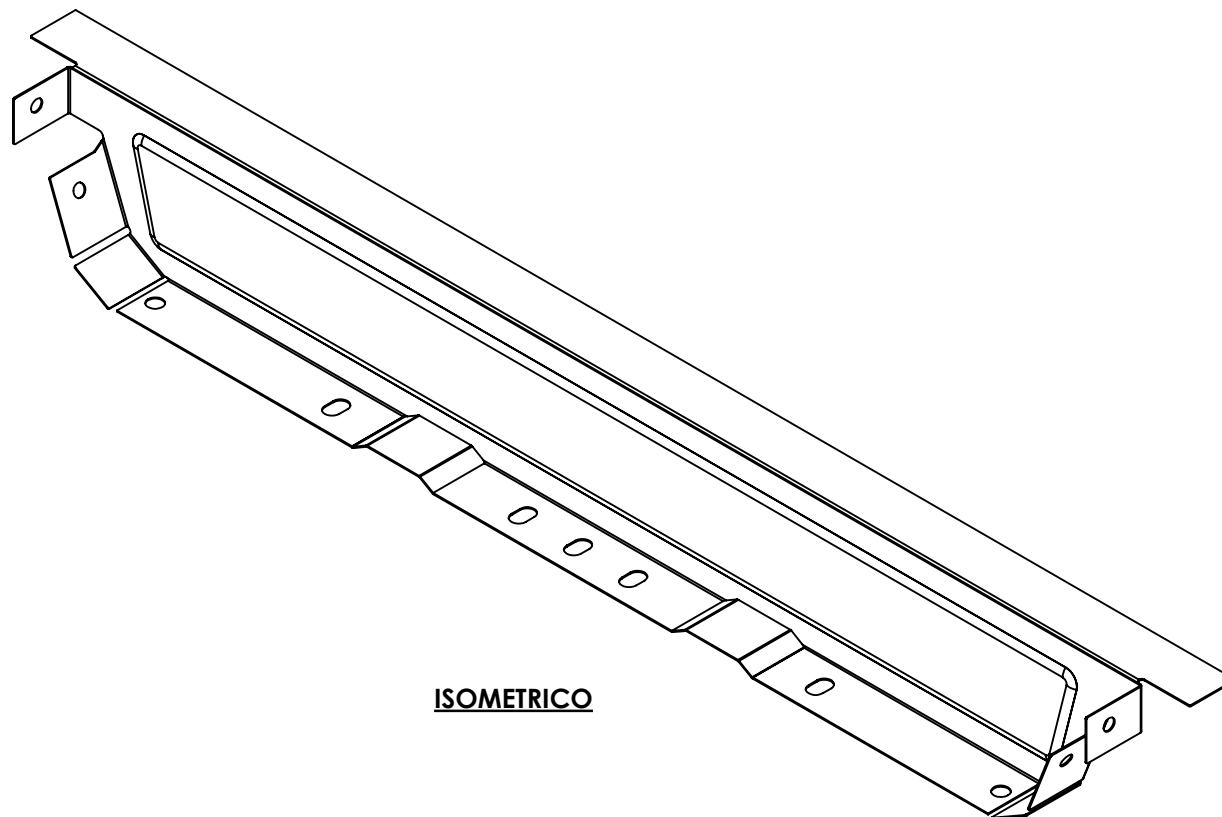

ISOMETRICO

REVISIONES				
ZONA	REV.	DESCRIPCION	FECHA	APROBADO

COTAS: PULGADAS FECHA: 02/DIC/2020 APROBO: L.G.C.R. HOJA: 2 DE 3 DIBUJO No: AG-CE	ESCALA: 1:3 DIBUJO: E.M.R.E.	DESCRIPCION: CLOSURE EXTERIOR TOLERANCIAS: FRACCION $\pm 1/32''$ DECIMAL $\pm 0.03''$ METRICO $\pm 0.008mm$ ANGULAR $\pm 1^\circ$	
	REVISO: A.C.E./J.A.A		
	FIRMA:		
	REVISION: 0		
TROQUELES DE REFERENCIA:	FR-PROD-05 FICHA TECNICA DE PRODUCTO	REV. 0	