

8

7

6

5

4

3

2

1

H

H

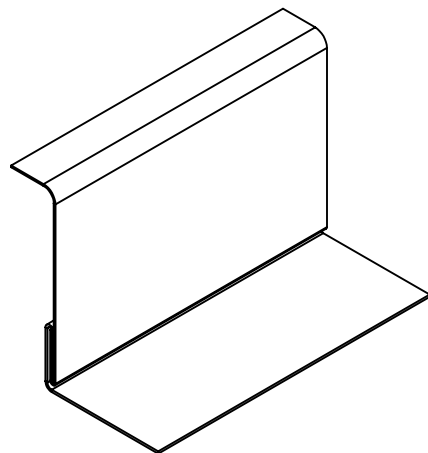
**ISOMETRICO**

LISTA DE MATERIALES					
PIEZA	NORMA/MATERIAL	GRADO	CALIBRE	ACABADO	PESO/UNIT.
BASE	ASTM A653	COMERCIAL	22	GALVANIZADO G-60	0.05 Kg
MOVIL	ASTM A653	COMERCIAL	24	GALVANIZADO G-60	0.05 Kg
PESO TOTAL					0.10 Kg

G

G

F

F

E

E

D

D

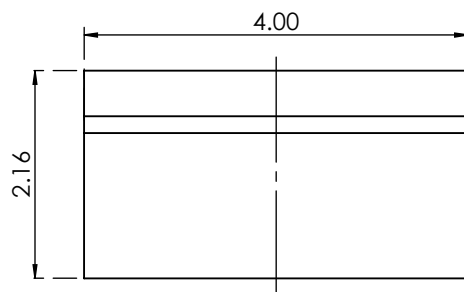
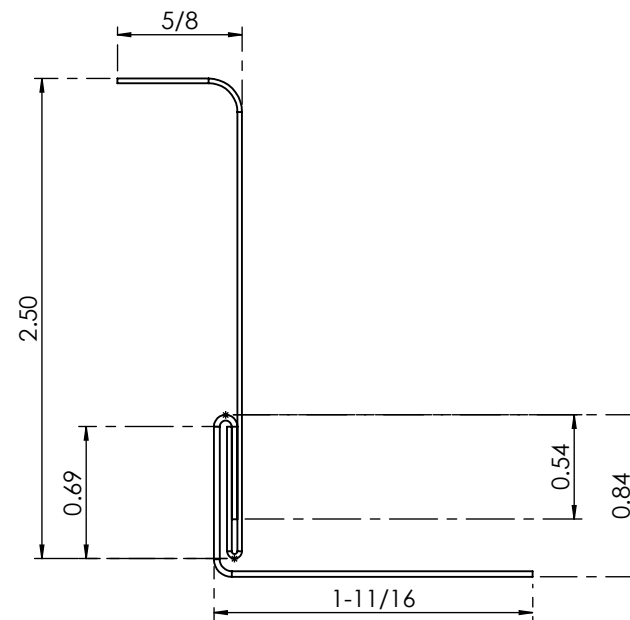
**PLANTA****ELEVACION**
ESC. 1:1

C

C

REVISIONES				
ZONA	REV.	DESCRIPCIÓN	FECHA	APROBADO

B

B

COTAS: PULGADAS	ESCALA: 1:2	DESCRIPCION: CLIP KR-18 MOVIL 180° 4"	TOLERANCIAS: FRACCION ± 1/32" DECIMAL ± 0.03" METRICO ± 0.008mm ANGULAR ± 1°	
FECHA: 10/NOV/2020	DIBUJO: E.M.R.E.			
APROBO: L.G.C.R.	REVISO: A.C.E./J.A.A.			
HOJA: 1 DE 2	FIRMA:	TROQUELES DE REFERENCIA:	FR-PROD-05	FICHA TECNICA DE PRODUCTO
DIBUJO No: AKR18-CM180	REVISION: 0			

A

A

8

7

6

5

4

3

2

1