

8

7

6

5

4

3

2

1

H

H

LISTA DE MATERIALES				
NORMA/MATERIAL	GRADO	CALIBRE	ACABADO	PESO/UNIT.
ASTM A653	40	24	PINTRO BLANCO ESTANDAR	0.05 Kg

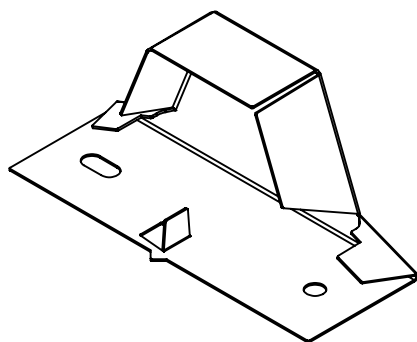
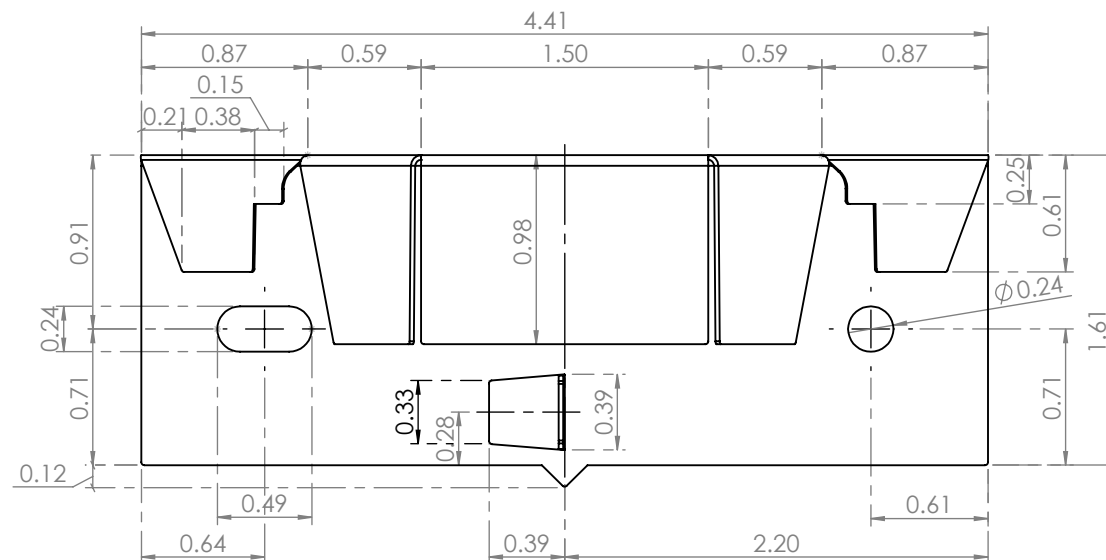
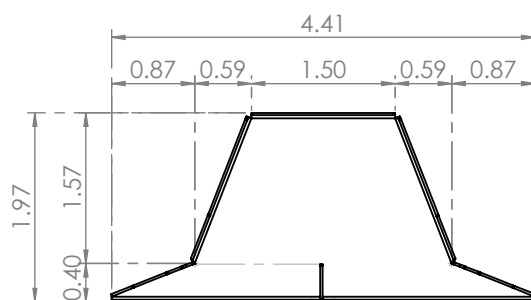
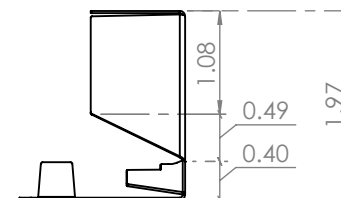
**ISOMETRICO****PLANTA**
ESC. 1:1**ELEVACION****VISTA LATERAL**

REVISIONES

ZONA	REV.	DESCRIPCIÓN	FECHA	APROBADO

COTAS:	PULGADAS	ESCALA:	1:2	DESCRIPCION: CLOSURE INTERIOR
FECHA:	02/DIC/2020	DIBUJO:	E.M.R.E.	
APROBO:	L.G.C.R.	REVISO:	A.C.E./J.A.A	
HOJA:	1 DE 2	FIRMA:		
DIBUJO No:	AG-CI	REVISION:	0	TROQUELES DE REFERENCIA:

TOLERANCIAS:

FRACCION $\pm 1/32''$
 DECIMAL $\pm 0.03''$
 METRICO $\pm 0.008mm$
 ANGULAR $\pm 1^\circ$



FR-PROD-05

FICHA TECNICA DE PRODUCTO

REV. 0

A

A

8

7

6

5

4

3

2

1