

8 7 6 5 4 3 2 1

H  
G  
F  
E  
D  
C  
B  
A

LISTA DE MATERIALES				
NORMA/MATERIAL	GRADO	CALIBRE	ACABADO	PESO/UNIT.
ASTM A653	SS37	16	GALVANIZADO G-60	1.42 Kg

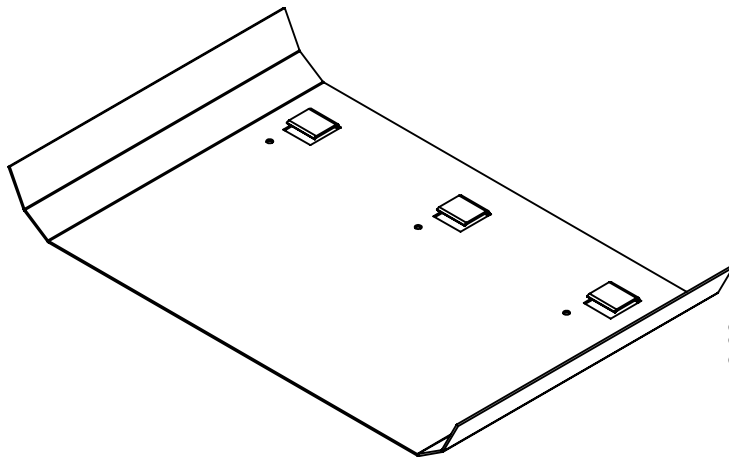

**ISOMETRICO**

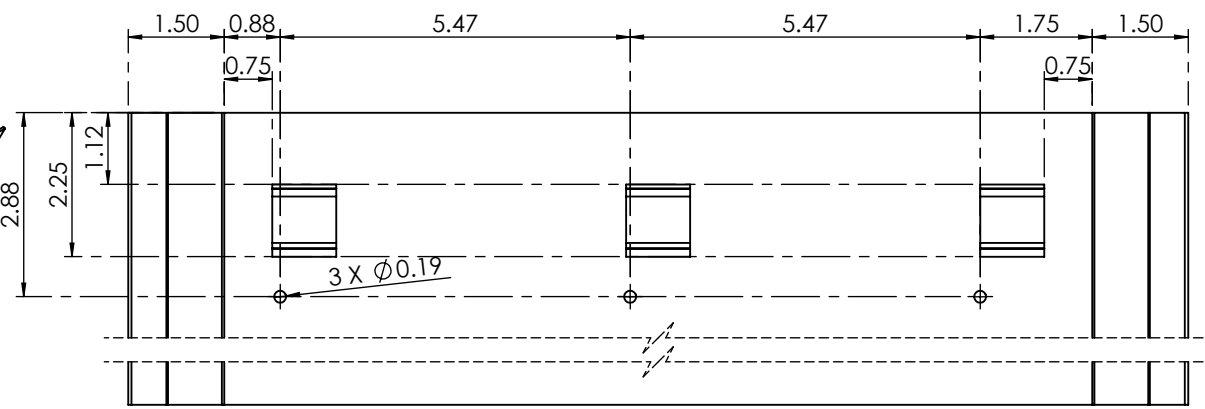

**PLANTA**

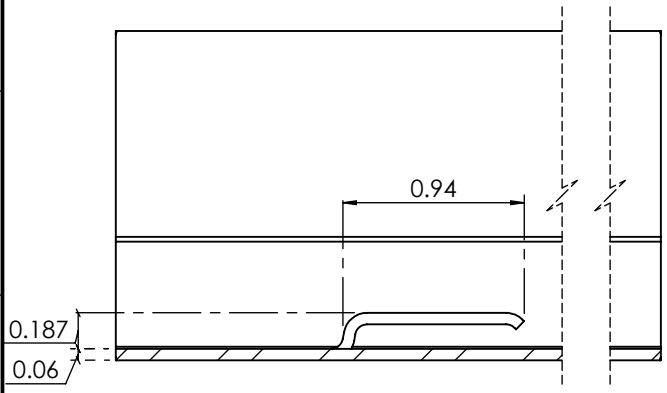

**SECCION "A-A"**  
ESC. 1:1

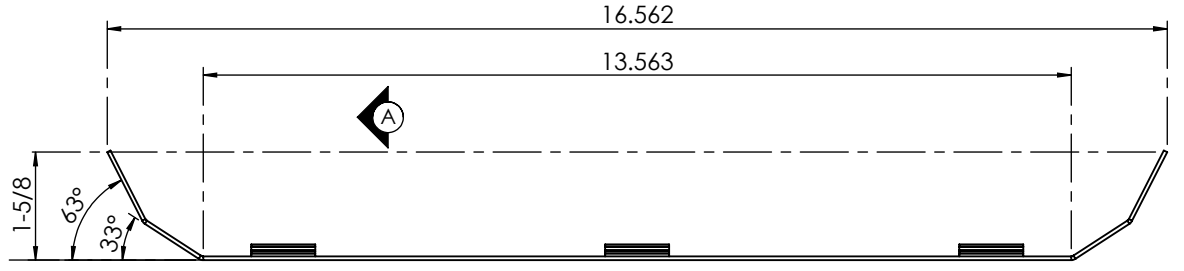

**ELEVACION**

REVISIONES				
ZONA	REV.	DESCRIPCION	FECHA	APROBADO

<b>COTAS:</b> PULGADAS <b>FECHA:</b> 03/NOV/2020 <b>APROBO:</b> L.G.C.R. <b>HOJA:</b> 1 DE 2 <b>DIBUJO No:</b> ASSR300-PA18	<b>ESCALA:</b> 1:3 <b>DIBUJO:</b> E.M.R.E. <b>REVISO:</b> A.C.E./J.A.A. <b>FIRMA:</b>	<b>DESCRIPCION:</b> PLACA DE APOYO SSR 300 18"  <b>TOLERANCIAS:</b> FRACCION ± 1/32" DECIMAL ± 0.03" METRICO ± 0.008mm ANGULAR ± 1°	 CALIDAD EN MECANIZADOS Y ENSAMBLAJES		
	<b>REVISION:</b> 0 <b>TROQUELES DE REFERENCIA:</b>			<b>FR-PROD-05</b> <b>FICHA TECNICA DE PRODUCTO</b>	
	<b>REVISION:</b> 0 <b>TROQUELES DE REFERENCIA:</b>				<b>REV. 0</b>
	<b>REVISION:</b> 0 <b>TROQUELES DE REFERENCIA:</b>				

8 7 6 5 4 3 2 1