

8

7

6

5

4

3

2

1

H

H

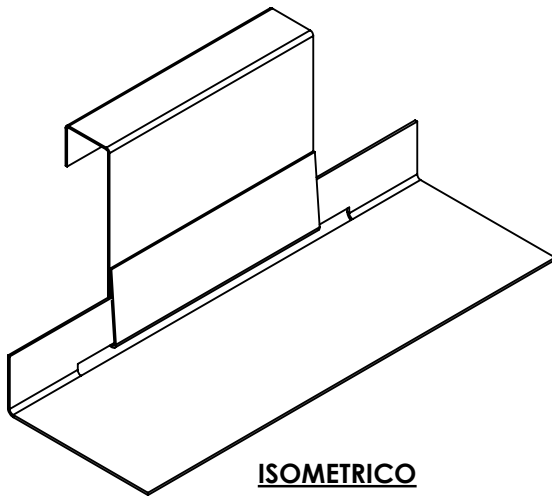
**ISOMETRICO**

LISTA DE MATERIALES					
PIEZA	NORMA/MATERIAL	GRADO	CALIBRE	ACABADO	PESO/UNIT.
BASE	ASTM A653	COMERCIAL	22	GALVANIZADO G-60	0.06 Kg
MOVIL	ASTM A653	COMERCIAL	24	GALVANIZADO G-60	0.04 Kg
PESO TOTAL					0.10 Kg

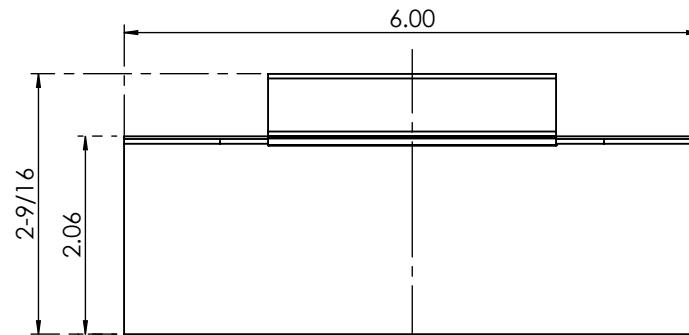
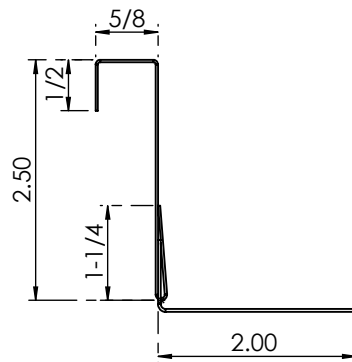
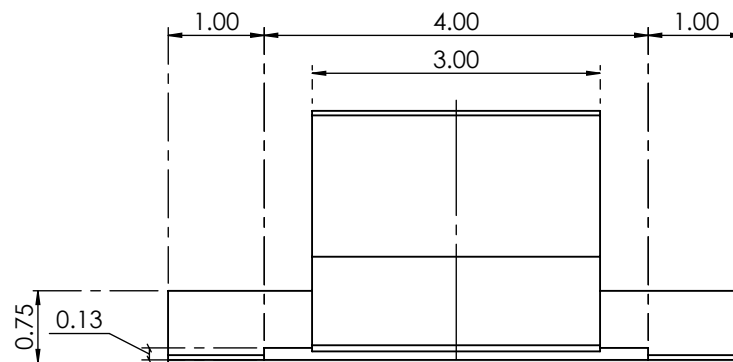
**PLANTA****ELEVACION****VISTA LATERAL**

REVISIONES

ZONA	REV.	DESCRIPCIÓN	FECHA	APROBADO

COTAS: PULGADAS

ESCALA: 1:2

DESCRIPCIÓN:

TOLERANCIAS:

FECHA: 10/NOV/2020

DIBUJO: E.M.R.E.

CLIP KR-18 MOVIL 90°
RANURA

FRACCION ± 1/32"

APROBO: L.G.C.R.

REVISO: A.C.E./J.A.A

DECIMAL ± 0.03"

HOJA: 1 DE 2

FIRMA:

METRICO ± 0.008mm

DIBUJO No: AKR18-CMR90

REVISION: 0

TROQUELES DE REFERENCIA:

ANGULAR ± 1°



FR-PROD-05

FICHA TECNICA DE PRODUCTO

REV. 0

8

7

6

5

4

3

2

1

A

A