

LISTA DE MATERIALES				
NORMA/MATERIAL	GRADO	CALIBRE	ACABADO	PESO/UNIT.
ASTM A653	SS37	14	GALVANIZADO G-60	6.59 Kg

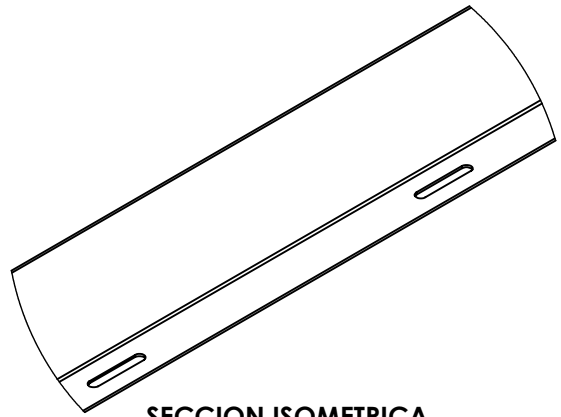

SECCION ISOMETRICA

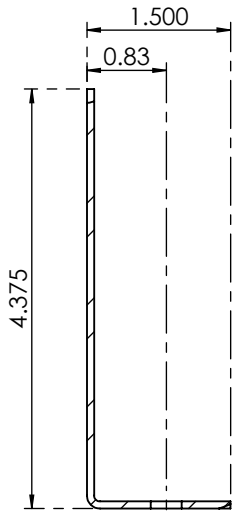

SECCION ELEVACION
ESC. 1:2

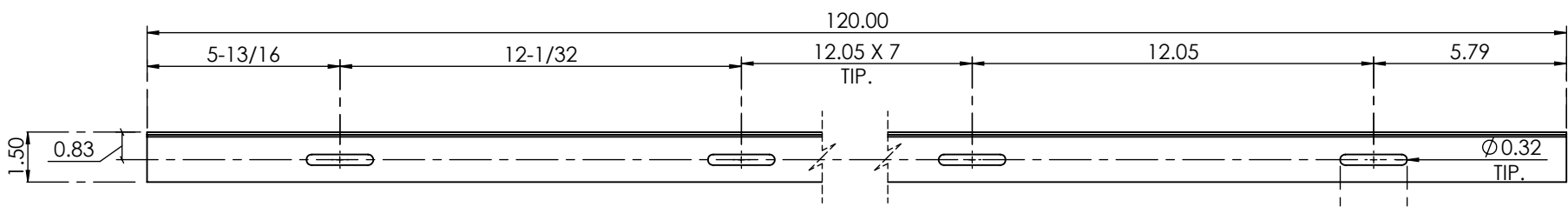

SECCION PLANTA

REVISIONES				
ZONA	REV.	DESCRIPCION	FECHA	APROBADO

COTAS: PULGADAS	ESCALA: 1:5	DESCRIPCION: ANGULO DE INICIO ALTO	TOLERANCIAS:	
	FECHA: 27/NOV/2020		DIBUJO: E.M.R.E.	
APROBO: L.G.C.R.	REVISO: A.C.E./J.A.A		DECIMAL ± 0.03"	
HOJA: 1 DE 2	FIRMA:		METRICO ± 0.008mm	
DIBUJO No: AG-AIA	REVISION: 0	TROQUELES DE REFERENCIA:	ANGULAR ± 1°	
			FICHA TECNICA DE PRODUCTO	
			REV. 0	