

REVISIONES				
ZONA	REV.	DESCRIPCIÓN	FECHA	APROBADO
D3	1	AJUSTE EN ALTURA	20/NOV/2020	
B2	2	AJUSTE DE MEDIDA	3/MAY/2021	

LISTA DE MATERIALES					
PIEZA	NORMA	GRADO	CALIBRE	ACABADO	PESO/UNIT.
LENGUA	ASTM A-653	SS37	24	GALVANIZADO G-60	0.040 Kg
BASE	ASTM A-653	SS37	14	GALVANIZADO G-60	0.246 Kg
PESO TOTAL					0.284 Kg

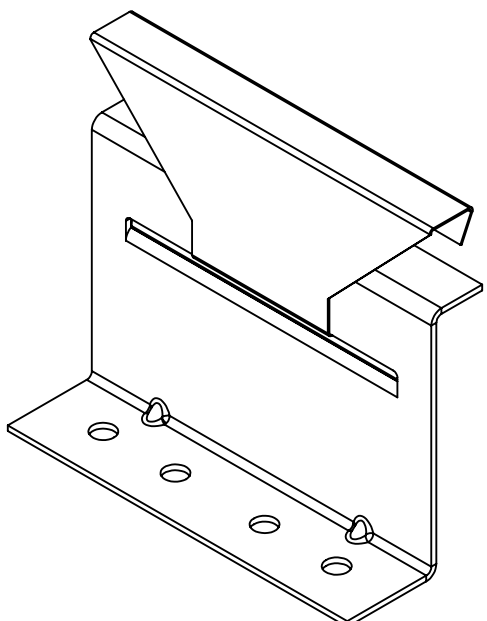

**ISOMETRICO**

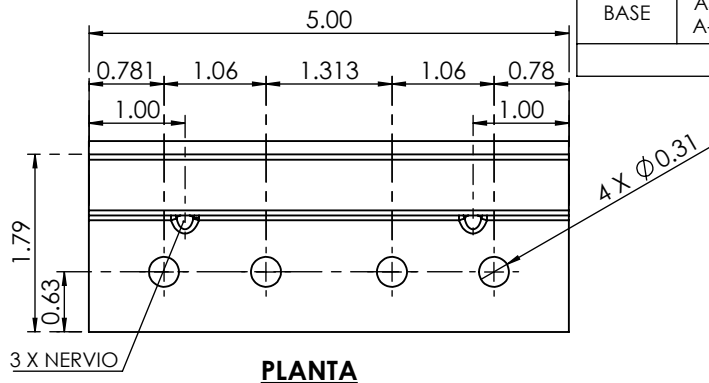

**PLANTA**

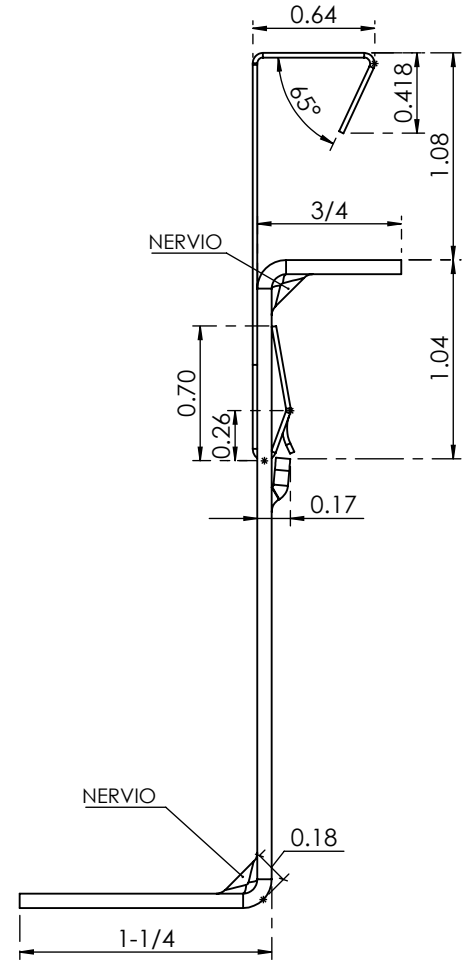

**VISTA LATERAL**  
ESC. 1:1

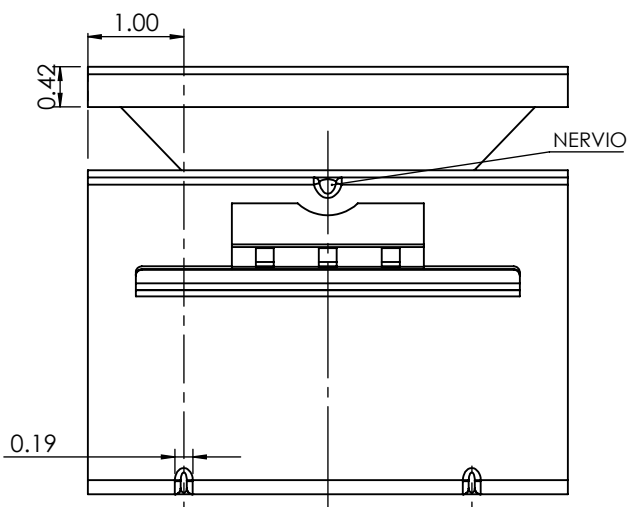

**VISTA REVERSO**

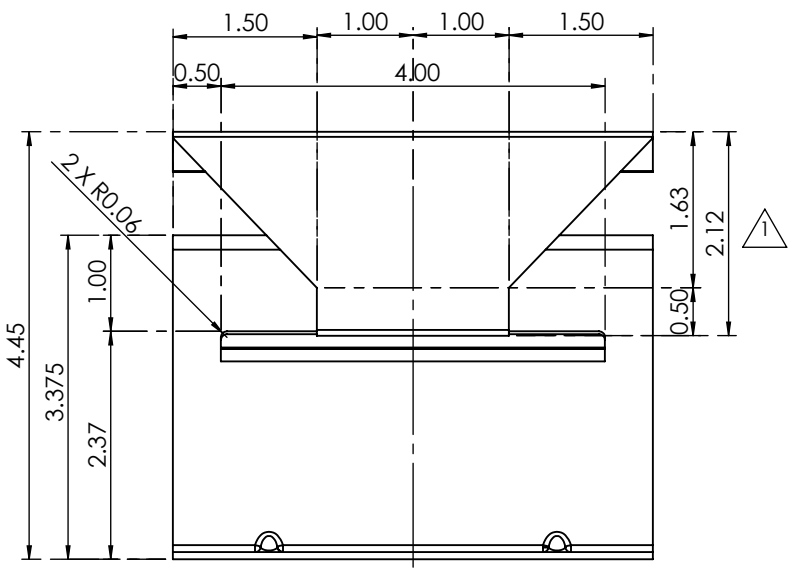

**ELEVACION**

<b>COTAS:</b> PULGADAS	<b>ESCALA:</b> 1:2	<b>DESCRIPCION:</b> CLIP GALVALOK LK-02 (ALTO)	<b>TOLERANCIAS:</b> FRACCION ± 1/32" DECIMAL ± 0.03" METRICO ± 0.008mm ANGULAR ± 1°
<b>FECHA:</b> 17/NOV/2020	<b>DIBUJO:</b> E.M.R.E.		
<b>APROBO:</b> L.G.C.R.	<b>REVISO:</b> A.C.E./J.A.A		
<b>HOJA:</b> 1 DE 7	<b>FIRMA:</b>		
<b>DIBUJO No:</b> AG-CHIGH	<b>REVISION:</b> 2	<b>TROQUELES DE REFERENCIA:</b>	



FR-PROD-05  
FICHA TECNICA DE PRODUCTO  
REV. 0