

**ISOMETRICO**

LISTA DE MATERIALES					
PIEZA	NORMA/MATERIAL	GRADO	CALIBRE	ACABADO	PESO/UNIT.
BASE	ASTM A653	COMERCIAL	22	GALVANIZADO G-60	0.06 Kg
MOVIL	ASTM A653	COMERCIAL	24	GALVANIZADO G-60	0.04 Kg
PESO TOTAL					0.10 Kg

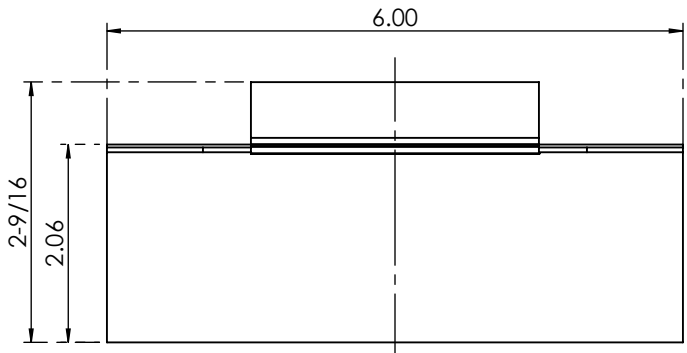

**PLANTA**

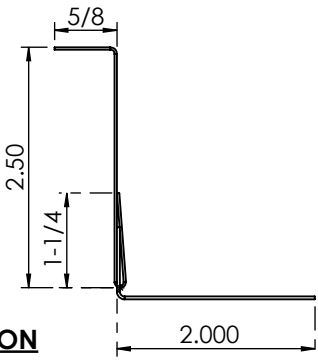

**ELEVACION**

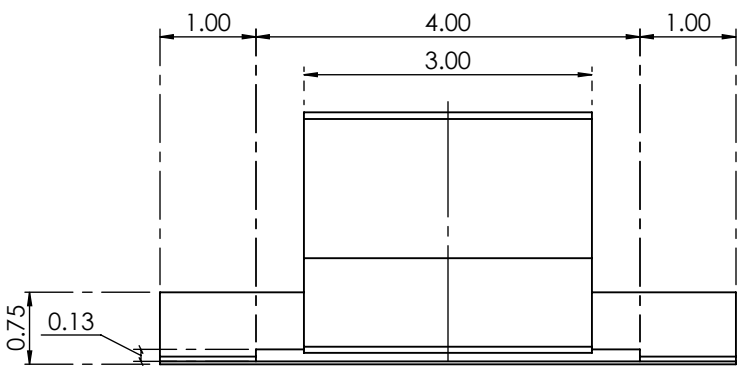

**VISTA LATERAL**

REVISIONES				
ZONA	REV.	DESCRIPCIÓN	FECHA	APROBADO

<b>COTAS:</b> PULGADAS <b>FECHA:</b> 10/NOV/2020 <b>APROBO:</b> L.G.C.R. <b>HOJA:</b> 1 DE 2 <b>DIBUJO No:</b> AKR18-CMR180	<b>ESCALA:</b> 1:2 <b>DIBUJO:</b> E.M.R.E. <b>REVISO:</b> A.C.E./J.A.A. <b>FIRMA:</b>	<b>DESCRIPCION:</b> CLIP KR-18 MOVIL 180° RANURA	<b>TOLERANCIAS:</b> FRACCION ± 1/32" DECIMAL ± 0.03" METRICO ± 0.008mm ANGULAR ± 1°	