

ISOMETRICO

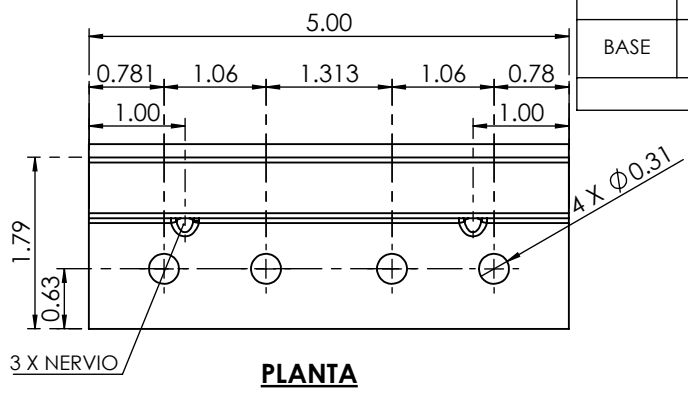

PLANTA

LISTA DE MATERIALES					
PIEZA	NORMA	GRADO	CALIBRE	ACABADO	PESO/UNIT.
LENGUA	ASTM A-653	SS37	24	GALVANIZADO G-60	0.040 Kg
BASE	ASTM A-653	SS37	14	GALVANIZADO G-60	0.194 Kg
PESO TOTAL					0.234 Kg

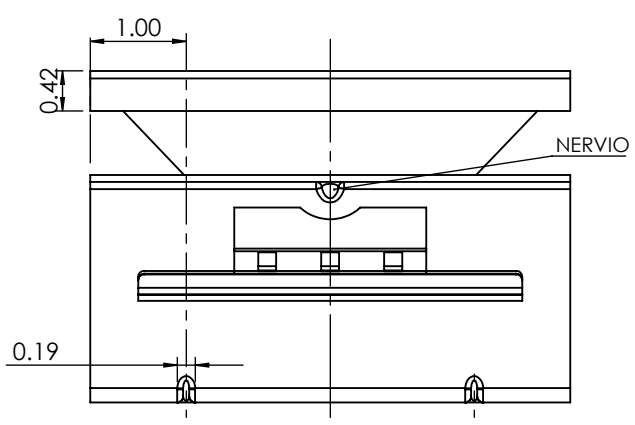

VISTA REVERSO

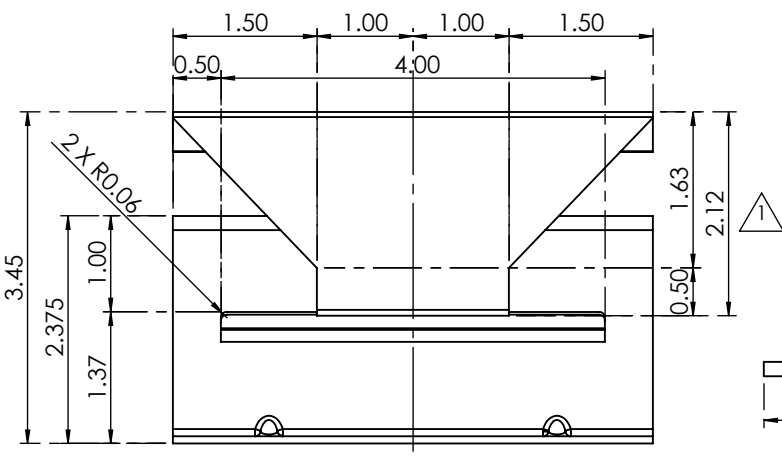

ELEVACION

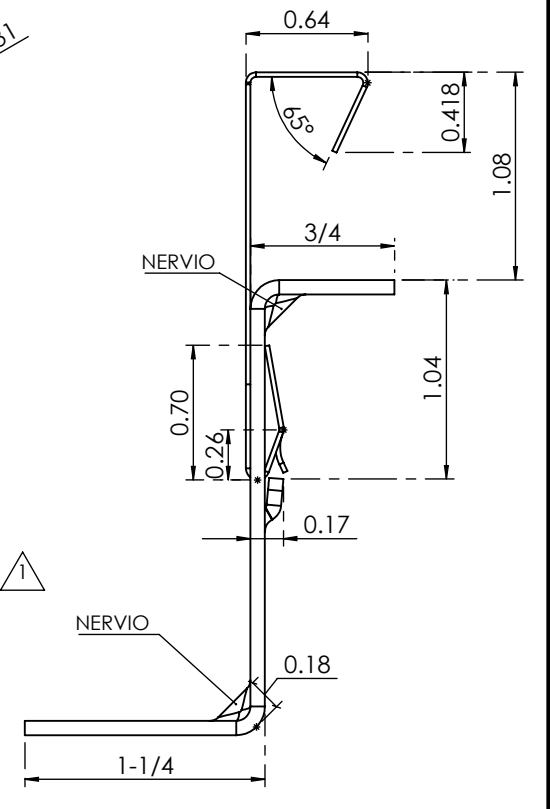

VISTA LATERAL
ESC. 1:1

REVISIONES				
ZONA	REV.	DESCRIPCIÓN	FECHA	APROBADO
D3	1	AJUSTE EN ALTURA	20/NOV/2020	

COTAS:	PULGADAS	ESCALA:	1:2	DESCRIPCION: CLIP GALVALOK LK-01 (BAJO)
FECHA:	17/NOV/2020	DIBUJO:	E.M.R.E.	
APROBO:	L.G.C.R.	REVISO:	A.C.E./J.A.A	
HOJA:	1 DE 7	FIRMA:		
DIBUJO No:	AG-CLOW	REVISION:	1	TROQUELES DE REFERENCIA:

TOLERANCIAS:
FRACCION ± 1/32"
DECIMAL ± 0.03"
METRICO ± 0.008mm
ANGULAR ± 1°



FR-PROD-05	FICHA TECNICA DE PRODUCTO	REV. 0